

# Heat from Underground Energy London (Heat FUEL)

**HENRIQUE LAGOEIRO** BENG (HONS), **AKOS REVESZ** PHD, **GARETH DAVIES** PHD, **GRAEME MAIDMENT** PHD, CENG  
School of Engineering, London South Bank University  
roscoeph@lsbu.ac.uk

**DANIEL CURRY**, **GARETH FAULKS**, **JOHN BIELICKI**  
Transport for London

## Abstract

This paper aims to introduce a heat recovery scheme that will collect waste energy from the London Underground in Islington, London. The system is based on the installation of an air to water heat exchanger within a ventilation shaft of the London Underground. The heat captured is distributed to a heat pump, which upgrades it to a suitable temperature for reuse and provides low carbon energy to a local district heating network. This paper introduces some of the key aspects of the technical design of this novel urban heat recovery and delivery system. Its theoretical performance is evaluated and compared to the previous heating method used for the buildings supplied by the network. It also provides recommendations for the implementation of future installations for secondary heat recovery and reuse in cities.

**Keywords** Heat networks, heat pumps, low carbon heating, London Underground, waste heat recovery

## 1. Introduction

### 1.1. Climate Change and Heat Consumption in London and the UK

Over the past few years, the United Kingdom has achieved significant reduction of Greenhouse Gas (GHG) emissions. According to the Committee on Climate Change (CCC)<sup>1</sup>, the UK has decreased its emissions by 43% since 1990. This is due to the Climate Change Act (2008), which established a target to reduce carbon emissions by 80% of its 1990 baseline level by 2050. In order to guarantee that the target will be met, the Act also set carbon budgets to be measured every five years to track the UK's progress in reducing carbon emissions. The UK has met its first and second carbon budgets, for the years of 2010 and 2015, and is on its way to meet the third carbon budget of 37% reduction by 2020. This is primarily attributable to the power sector, due to a reduction in the use of coal and an increase in the use of renewable sources for electricity generation<sup>1</sup>. Carbon factors have reduced considerably, however, if we are to meet the fourth & fifth carbon budgets, there will need to be much greater efforts from other sectors such as heating and cooling and transport.

The heating and cooling sector accounts for approximately one third of carbon emissions and around half of the energy consumption in the UK<sup>2</sup>. Despite having a

considerable influence on how energy is consumed in Britain, currently very little heating and cooling is produced from renewable energy sources. When compared to other European Union countries, the UK has the lowest share of renewable sources providing heating/cooling, which represent only 5.5% of all the energy sources that are used<sup>3</sup>, as demonstrated in Figure 1.

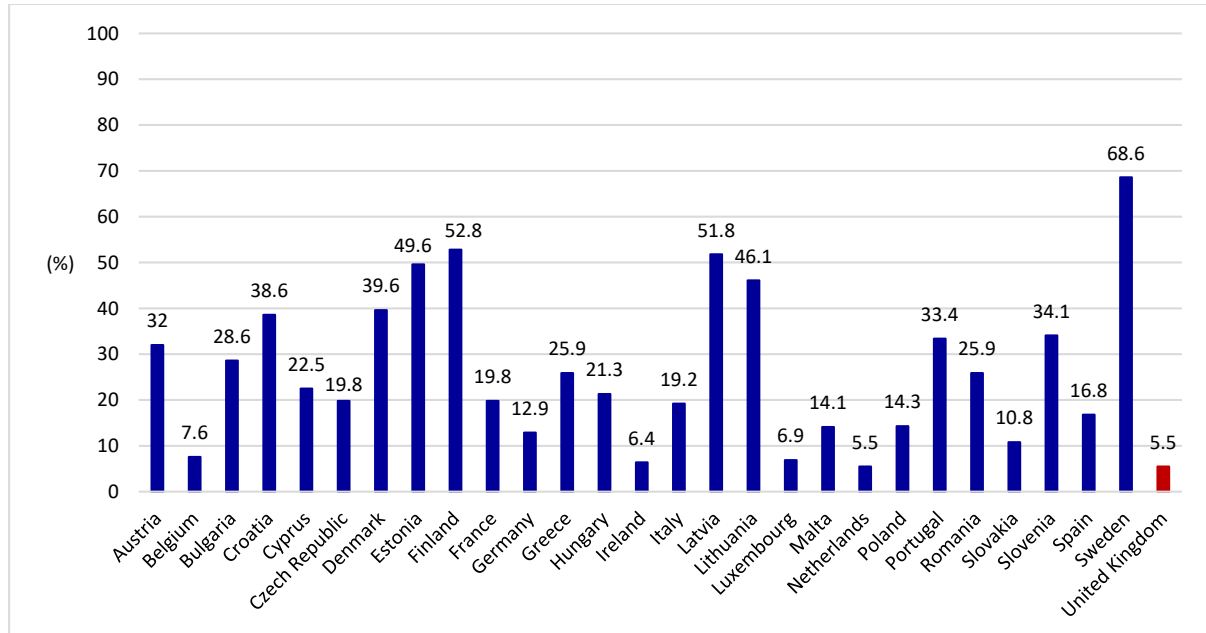

**Figure 1 – Shares of renewable energy sources for heating and cooling in the EU, in 2015<sup>3</sup>.**

To stimulate low carbon heating, the UK Government has implemented the Renewable Heat Incentive (RHI), which is a financial refund linked to the quantity of heat generated from renewable sources. However, in 2017, only 4.5% of heating in buildings came from low-carbon sources<sup>1</sup>. Sustainable heating is also a problem at a city level; London currently relies on gas-fired boilers, which account for 90% of heat sources used in the city, contributing not only to global warming but also to air pollution. Furthermore, 10.1% of London’s households were in fuel poverty in 2015<sup>4</sup>. Recent developments based on Combined Heat and Power (CHP) systems have been introduced across the city as a cost-effective way to produce low-carbon heat. However, as the national electricity grid decarbonises, the carbon savings related to CHP are declining and there is increasing evidence of its adverse impacts on air quality.

The Greater London Authority (GLA), in its Environment Strategy<sup>4</sup>, has set the ambitious goal for London of becoming zero carbon by 2050. The heating sector has a very important role in achieving this target, since London’s 3.5 million homes produce one third of the capital’s total GHG emissions and nearly three quarters of the energy consumed by homes is used for space and hot water heating. Meanwhile, the energy used to power and heat London’s workplaces account for about 40% of the city’s emissions, with 51% of the energy being used for space and hot water heating<sup>4</sup>.

## 1.2. Heat Networks

Heat networks, or district heating networks (DHNs), represent an interesting alternative to deliver cost effective low carbon heat. They are very flexible, being able to incorporate new buildings and heat sources as the network grows, and are particularly attractive in densely populated urban areas. DHNs also enable the use of different generating technologies to feed heat into the network, avoiding a lock-in to technologies that may become obsolete in future decades. It also permits multiple heat sources to be used simultaneously in order to deliver heat to the network, providing a key mechanism to allow a smooth transition from current fossil fuel based heat to future low carbon heat sources. In fact, a DHN can accommodate any heat source of sufficient temperature, enabling the use of waste heat sources to provide heating. The recovery of waste heat involves capturing heat that would otherwise be rejected during a given process, such as the heat that is generated during the operation of many urban infrastructures, e.g. sewage systems, electricity substations and cables, data centres, and railway tunnels.

In the UK, heat networks supply only around 2% of the overall heating demand<sup>5</sup>, whilst in London, 6% of the energy is supplied via local networks<sup>4</sup>. However, national and local authorities have recognised the importance of heat networks and are planning to promote the use of DHNs as a key future policy. The CCC<sup>1</sup> has indicated that low-carbon district heating should be prioritised immediately, requiring early clarity by the Government on support beyond 2020, whilst the London Environment Strategy<sup>4</sup> has already set a target of meeting 15% of the capital's energy demand using district schemes and renewable sources. This paper describes one such application for heat networks in London, which utilizes waste heat, known as the Bunhill Heating Schemes 1 and 2. This paper analyses the availability of heat from a London Underground (LU) ventilation shaft, which is used in Bunhill 2, as well as describes the heating scheme, its key components and expected performance.

## 1.3. The London Underground as a Heat Source

With the urgent need to address climate change, and with encouragement by the government, a great opportunity has arisen to change the way that heating is generated and supplied in London, which is based on the use of heat networks connected to waste heat sources. Amongst some potential waste heat sources that were mentioned above, underground railways represent a particularly good option. The Metropolitan Integrated Cooling and Heating (MICAH) project investigated how the Underground network remains relatively warm in most locations throughout the year and that the system could also deliver cooling to the tunnels when required<sup>6</sup>.

Cooling the Underground stands, indeed, as a great opportunity as the operation of the trains produces significant amounts of heat, reaching approximately 500 GWh per annum<sup>7</sup>. The primary heat sources in the London Underground are mostly related to

the running of the trains, with the majority of heat being traced back to braking frictions and other mechanical losses. With the recent increase in service levels on all lines, and the expectancy of further rise in service in the future, it is likely that even more heat will be available for recovery within the Underground network.

This opportunity is due to the London Clay soil surrounding the tunnel walls being an insulator<sup>7</sup>, resulting in higher tunnel air temperatures. This is highlighted in Table 1, which shows the average temperatures of the extracted air from a ventilation shaft in Islington for the different seasons of the year, as provided by Islington Borough Council (written communication, October 2018). By exploiting this opportunity, cooling is also delivered to the Underground, which is equally beneficial.

| Season        | Ventilation Extract Temperatures (°C) |         |     |
|---------------|---------------------------------------|---------|-----|
|               | Min                                   | Average | Max |
| Winter        | 18                                    | 19      | 21  |
| Spring/Autumn | 19                                    | 23      | 25  |
| Summer        | 24                                    | 26      | 28  |

**Table 1 – Measured minimum, maximum and average temperatures in a ventilation shaft in Islington (written communication, October 2018).**

## 2. Bunhill Heating Scheme

Within the context of fuel poverty and high rates of carbon-based heating in London, the Bunhill Heat Network was an initiative from Islington Council to provide locally produced lower cost and greener heat to warm nearby housing estates and service buildings. The main concept behind the first phase of the project, also referred to as Bunhill 1, was to use a gas-fired CHP system, which produces both electricity and heat, linked to a heat distribution network in order to supply heating for the local community. The Islington Council's GIS system<sup>8</sup> shows that 788 homes within three housing estates and one residential building are being supplied with heat from the network, which also feeds another four commercial buildings and two leisure facilities in Islington.

In an effort to further expand the supply of low cost and low carbon heat to its residents, Islington Council started to research potential extensions to the Bunhill Scheme, which led to the opportunity of developing a waste heat recovery system based on heat capture from the London Underground, in a partnership with Transport for London (TfL) and the GLA. This project is the first of its kind in Europe and is part of the EU CELSIUS Project. The decision to use waste heat sources is also related to the decreasing carbon efficiency of CHP systems due to the decarbonisation of electricity in the UK.

The extension, also referred to as Bunhill 2, will collect heat from a ventilation shaft on the Northern Line of the Underground network. The heat will then be upgraded using

a heat pump before being transferred into the DHN, which will be extended to connect the new buildings to the ventilation shaft. Two CHP engines will also be added to the system so as to provide resilience and flexibility to the heat network. The scheme is expected to provide heating to 455 dwellings in 5 building blocks of local housing estate and a local primary school. A new mixed use building complex that is currently being developed will also be connected to Bunhill 2, adding 720 residential units, a 160-bed student accommodation and a 125-bed hotel, as well as areas for offices, retail and restaurants as new end users of the network.

| Network Connection   | Building Code | Type of Building       | Annual Heat Consumption (MWh) |
|----------------------|---------------|------------------------|-------------------------------|
| Bunhill 1 (EC 1)     | 01            | Residential/commercial | 3,044                         |
|                      | 02            | Residential            | 876                           |
|                      | 03            | Leisure                | 82                            |
|                      | 04            | Leisure                | 1,352                         |
|                      | 05            | Residential            | 837                           |
|                      | 06            | Residential            | 1,184                         |
|                      | 07            | Residential            | 5,478                         |
| <b>Total</b>         |               |                        | <b>12,853</b>                 |
| Bunhill 2 (EC 2)     | 08            | Residential            | 2,522                         |
|                      | 09            | School                 | 169                           |
|                      | 10            | Residential            | 1,497                         |
|                      | 11            | Residential            | 468                           |
|                      | 12            | Residential            | 919                           |
|                      | 13            | Mixed Use              | 5,783                         |
| <b>Total</b>         |               |                        | <b>11,358</b>                 |
| <b>Whole Network</b> | <b>Total</b>  |                        | <b>24,211</b>                 |

**Table 2 – Details of all buildings to be connected to the Bunhill District Heating Scheme.**

Table 2 shows the heating demand and type of use for all the buildings that are connected to Bunhill 1, and those which will be connected to Bunhill 2 after the extension of the network is completed. The development of Bunhill 2 will shed light on how London can become a truly smart city, showing how DHNs can be fundamental in future smart energy infrastructures, both at district and ultimately city levels, by allowing the capture of urban waste heat.

### 3. Network Components

In order to understand the operation of the Bunhill Heating Scheme, it is essential to bear in mind the capacities of the heat sources and the design parameters of the network components, as shown in Figure 2. The Bunhill 1 Energy Centre comprises a 1.9 MW<sub>e</sub>/2.3 MW<sub>th</sub> gas fired CHP and a 115 m<sup>3</sup> thermal store. The network currently has flow and return temperatures of respectively 95°C and 75°C.

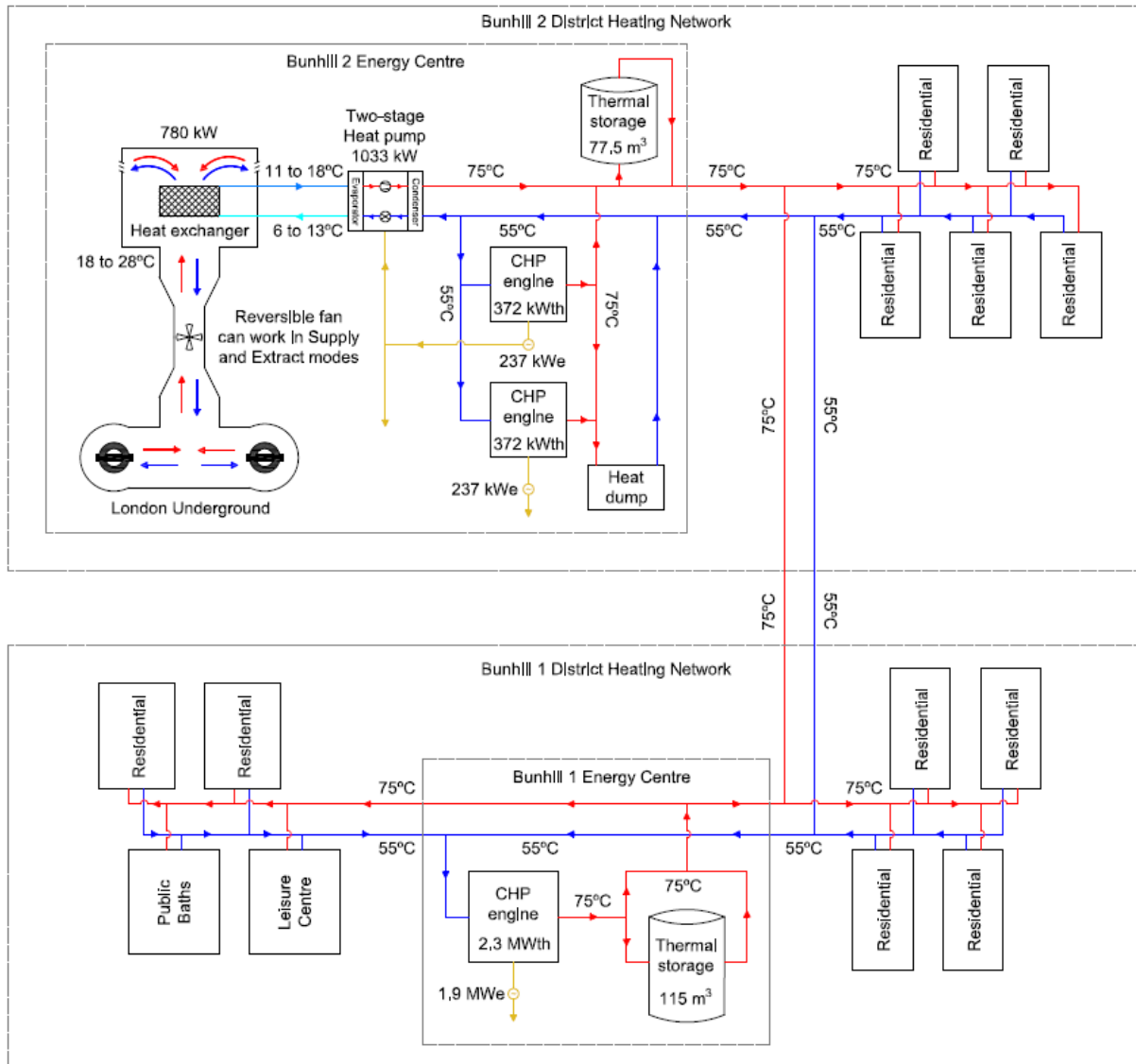

Figure 2 – Schematic of the Bunhill Heating System, considering both DHNs, Bunhill 1 and 2.

Bunhill 2 will involve an Energy Centre with an annual average heat output of 1,033 kW<sub>th</sub>, with 780 kW of heat being recovered from the ventilation shaft and then upgraded by a two-stage heat pump, which will add the remaining 253 kW to the heat that is delivered to end users through the DHN. The two CHP units, each with an output of 237kW<sub>e</sub>/372kW<sub>th</sub>, will power the heat pump and also add resilience and flexibility to Energy Centre 2, although its heat output could be dumped if unneeded. A thermal store of 77.5 m<sup>3</sup> will also be installed in order to add flexibility, helping to manage peak demand. As shown in Table 1, the air that exhausts through the ventilation shaft has temperatures varying from around 18°C to 28°C. Thus, the first water loop, which transports the heat from the vent shaft to the heat pump, will also work with flow and return temperatures that vary according to the season of the year. The expected operating flow and return temperatures throughout the year vary from 11 to 18°C and 6 to 13°C, respectively. The reasons and impacts of these varying water temperatures to the system's cooling and heating duties will be further

addressed in this paper. After Bunhill 1 and 2 are connected, the overall flow and return temperatures will be of 75°C and 55°C, respectively.

As this paper aims to research the novelty related to the system, only the Bunhill 2 network will be investigated, focusing on the first trial to recover waste heat from the London Underground. In order to analyse the expected operation of Bunhill 2, this paper will consider the main components that make up the system for recovering waste heat from railway tunnels.

### 3.1. Heat Exchanger

The first stage of the system involves capturing the heat generated on Northern Line, which is done by placing an air-to-water heat exchanger in the City Road ventilation shaft. The heat exchanger used for this waste heat recovery system is a fan coil unit. The ventilation shaft has been adapted by TfL in order to accommodate the heat recovery heat exchanger. This involved building a head house where the coils were installed and upgrading the variable speed reversible fan within the ventilation shaft. The additional fan power required to overcome the pressure drop of the coils is very little compared to the heat output that is generated. Even if a low fan efficiency of 50% is considered, the additional power required would be of only 19.5 kW. The calculations were based on Equation 1<sup>9</sup> and considered a design pressure drop of 138.9 Pa and an air flow of 70 m<sup>3</sup>/s.

$$Fan\ power\ (W) = \frac{fan\ total\ pressure\ (Pa) \times volumetric\ airflow\ \left(\frac{m^3}{s}\right) \times 100}{fan\ efficiency\ (\%)} \quad (1)$$

The reversible fan enables the system to work in both Extract and Supply modes. The benefits of operation in these two modes have been previously investigated by Davies et al.<sup>6</sup>, and consists of reversing the flow direction of the fan, allowing the system to operate by either extracting hot air from the Underground, which can then be used to warm the water in the coils, or using ambient air, which would be cooled by the coils and then supplied to the Underground, with the heat extracted being recovered by the heat exchanger. Extract mode would be used during the colder months of the year, when the heat demand is at its peak and heat can be collected at temperatures between 18 and 25°C (excluding the summer months), as indicated in Table 1. When in Supply mode, the cooled air would be used to supply cooling to the Underground during the summer, with ambient air as the heat source, at an average temperature of approximately 17°C<sup>10</sup>. This would lead to maximum flow and return temperatures in the first water loop of, respectively, 18°C and 13°C. The system would not operate in Extract mode during summer, although by doing so the water could reach even higher temperatures. Figure 3 shows a schematic of the ventilation shaft and the head house, showing the coil heat exchanger and the reversible fan.

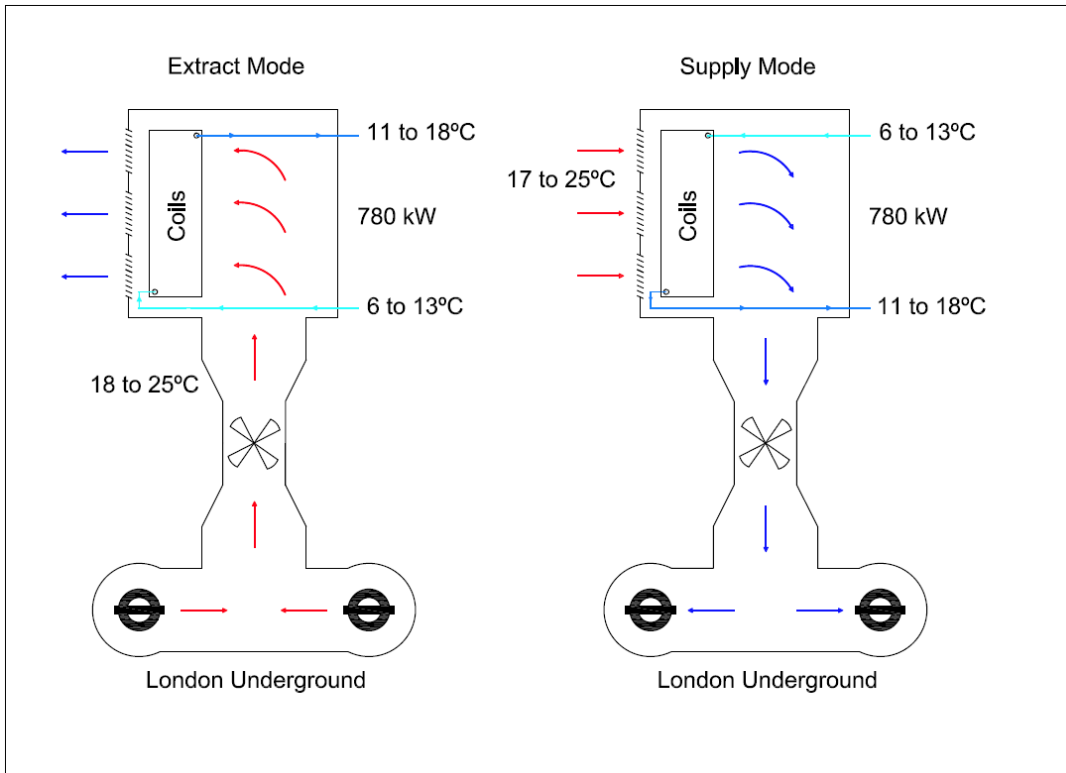

**Figure 3 – Schematic of the heat exchanger and the ventilation shaft of the Bunhill Energy Centre 2.**

The design parameters of the heat exchanger have been selected to ensure it meets the requirements of both the heat supplier and end users. Table 3 shows the design parameters of the fan coil heat exchanger for three different operations, based on a UA value of 164 kW/K, considering air on coil temperatures of 18°C, 20°C and 25°C.

| Operating Mode | Capacity (kW) | Water Flow (kg/s) | Fluid Temperature (°C) |         | Air Flow (m <sup>3</sup> /s) | Air Temperature (°C) |          |
|----------------|---------------|-------------------|------------------------|---------|------------------------------|----------------------|----------|
|                |               |                   | On Air                 | Off Air |                              | On Coil              | Off Coil |
| 1              | 778           | 37.2              | 6                      | 11      | 70                           | 18                   | 9        |
| 2              | 780           | 37.2              | 8                      | 13      | 70                           | 20                   | 11       |
| 3              | 784           | 37.2              | 13                     | 18      | 70                           | 25                   | 16       |

**Table 3 – Design parameters for the air-to-water fan coil heat exchanger in Extract mode.**

The coils have an average operating cooling duty of 780 kW and consist of 6 modules with 6 rows of copper tubes, resulting in a total of 36 rows of tubes - comprising the coil heat exchanger. The coils were built up in modules to make maintenance simpler and minimise downtime for cleaning. The tubes have a 12 mm diameter with fin spacing of ¼ inch (approximately 6 mm), and a thickness of 0.18 mm. The fins were designed to provide adequate spacing in order to avoid the use of filters, which can be applied to prevent fouling but require regular cleaning and increase the potential fire hazard. Recent research<sup>11</sup> has proven that fouling effects can be minimised and



filters avoided as long as the coil has a wide fin spacing of at least  $\frac{1}{4}$  inch (approximately 6 mm).

### 3.2. Heat Pump

Following the heat capture in the ventilation shaft, the first water loop will transport the recovered heat to a two-stage water to water heat pump, which was designed based on the flow and return DHN temperatures of 75°C and 55°C, respectively. For district heating purposes, as the evaporator and the condenser operate with a large temperature difference, deploying single-stage heat pumps could lead to lower compression efficiency and decrease the overall system performance<sup>12</sup>. Two-stage compression represents a more flexible system, being able to operate at different capacities, and with greater efficiency. One advantage is that it allows intercooling, which decreases the necessary work input to the compressors, delivering high temperature lifts with a high Coefficient of Performance (COP)<sup>13</sup>. The flash intercooler also improves the efficiency of the system by allowing flash gas to be removed before the refrigerant enters the evaporator, increasing its heat transfer rate. The two-stage heat pump installed at Bunhill 2 operates differently according to the season of the year, due to the varying temperatures of its heat source. Table 4 shows the design parameters of the two-stage heat pump for the three different operating modes established in Table 3.

| Design Parameters                        | Operating Mode 1 | Operating Mode 2 | Operating Mode 3 |
|--|------------------|------------------|------------------|
| Cooling Duty - Q <sub>e</sub> (kW)       | 778              | 780              | 784              |
| First Loop Water Flow Temperature (°C)   | 11               | 13               | 18               |
| First Loop Water Return Temperature (°C) | 6                | 8                | 13               |
| Heating Duty - Q <sub>c</sub> (kW)       | 1042             | 1033             | 1012             |
| DHN Flow Temperature (°C)                | 55               | 55               | 55               |
| DHN Return Temperature (°C)              | 75               | 75               | 75               |
| Estimated Shaft Power (kW)               | 264              | 253              | 228              |
| Estimated Electrical Consumption (kW)    | 286              | 275              | 248              |
| Cooling COP                              | 2.72             | 2.84             | 3.16             |
| Heating COP                              | 3.64             | 3.76             | 4.08             |

Table 4 – Design parameters for the two-stage heat pump installed at Bunhill 2.

The two-stage heat pump uses R717 (ammonia) as a refrigerant. The low stage includes a 25 bar compressor that can run at a wide range of capacities in order to accommodate the variation in ventilation temperatures exhausted from the LU shaft. The high stage includes two 50 bar compressors, which can also accommodate varying capacity, while maintaining the desired outlet water temperature at 75°C. The heated water from the first water loop will deliver heat to the heat pump's evaporator, with an approach temperature ( $\Delta T$ ) of 5°C, however, the cooling duty increases slightly, as higher temperature water enters the evaporator<sup>14</sup>, to between 778 kW and

784 kW, with an annual average of 780 kW. By varying the cooling duty, the power input to the compressors can be minimised without compromising the design outlet temperatures. This results in higher COPs as cooling duty is increased, with an annual average COP of 3.76. There are 5 shell and plate heat exchangers within the heating circuit, namely the flooded evaporator, a condenser, a subcooler and two desuperheaters. Figure 4 shows a schematic of the two-stage water to water heat pump installed at the Energy Centre of the Bunhill 2 heat network.

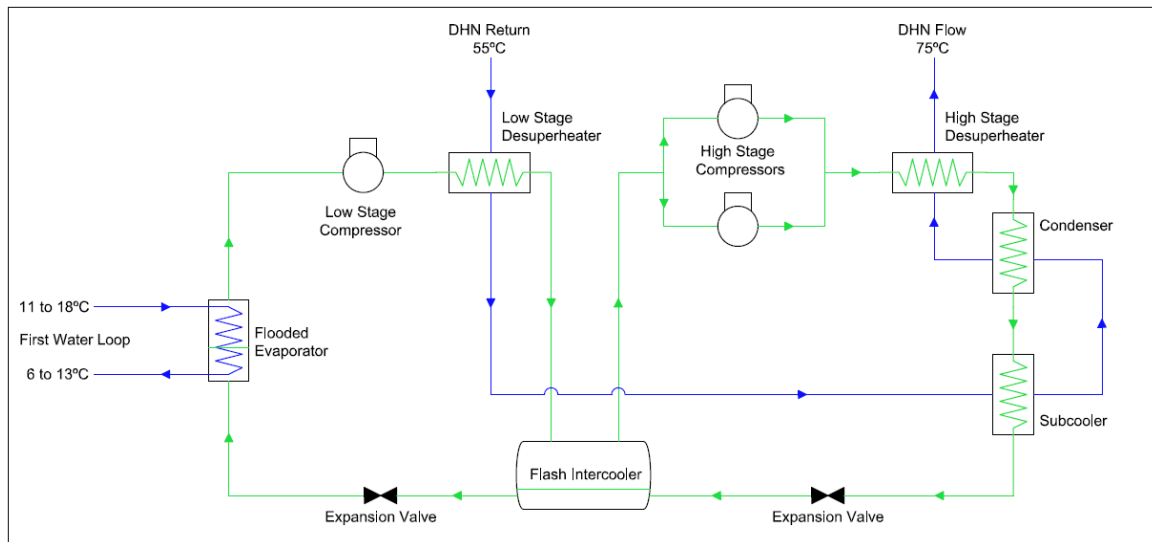

Figure 4 – Schematic of the two-stage heat pump of the Bunhill Energy Centre 2.

### 3.3. Thermal Storage

In order to provide flexibility, a thermal storage tank filled with 77.5 m<sup>3</sup> of water will be installed at Bunhill 2. Storing thermal energy is crucial to manage peak demand, securing the reliability of the system when it is most requested. The thermal store also avoids short cycling of the heat pump, enhancing its efficiency, since frequent start/stop operation can harm the system's reliability and increase its need for maintenance.

### 3.4. Heat Distribution Pipework

The heat distribution network will have an approximate length of 2.4 km and will utilise two parallel insulated pipes, for the flow, i.e. heat delivery, and return water streams. The flow and return temperatures are 75°C and 55°C, respectively, and water will leave the heat pump outlet at a design flow rate of 37.2 kg/s. The network has different pipe diameters, varying from DN 80 for local building connections to DN 250 for the main flow/return pipes, which distribute the heated water from the heat sources to local circuits, which feed one or more buildings connected to the network. Figure 5 shows an overview map of the existing Bunhill 1 network and the proposed Bunhill 2, including the heat distribution pipework, the heat sources and local buildings, which are either already connected, or are proposed to be connected to the DHN in the future. The building codes adopted in Table 2 will be used to identify each of the

connected buildings on the map. Energy Centre 1 (EC1) corresponds to the Bunhill 1 CHP unit, whilst the Energy Centre 2 (EC2) represents the site where heat will be captured from the City Road ventilation shaft, and also includes the heat pump and the two CHP units.

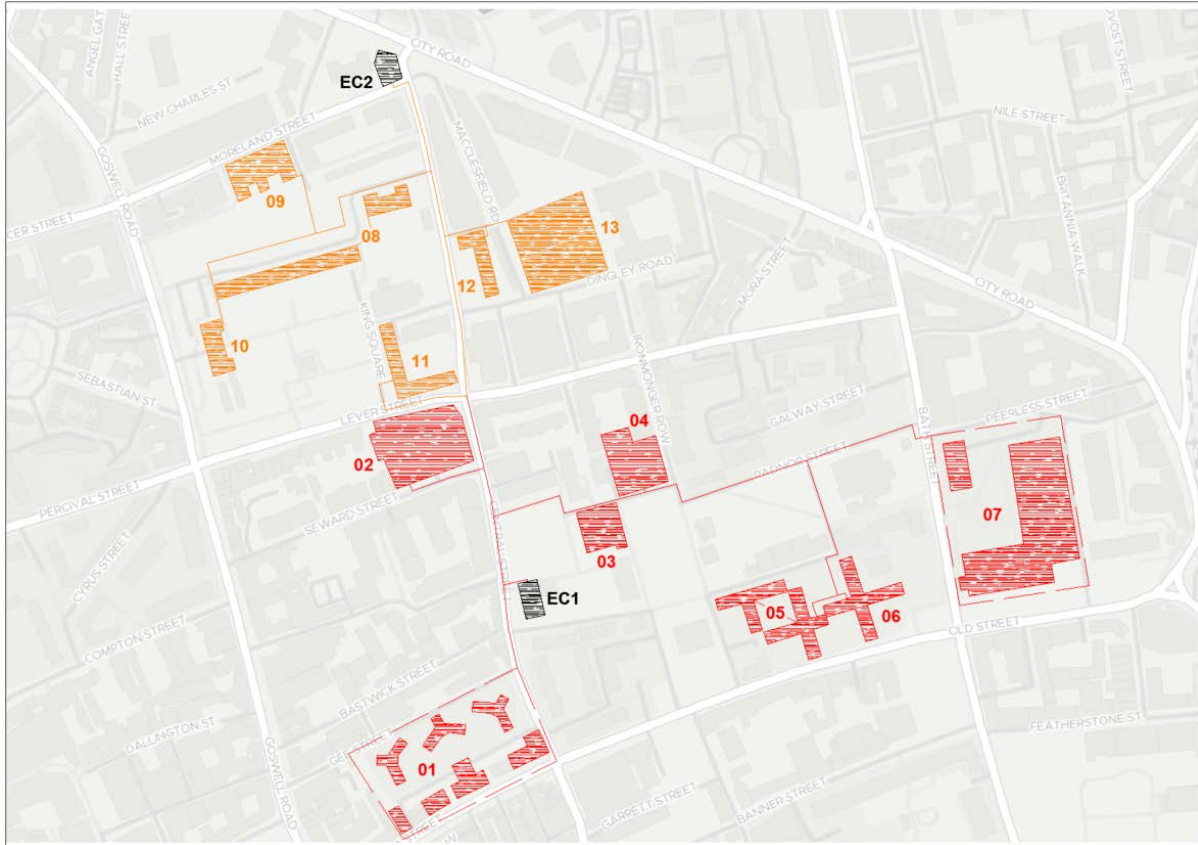

Figure 5 - The existing and planned heat networks for Bunhill 1 (red) and 2 (orange), adapted from Islington Council's GIS System.<sup>8</sup>

#### 4. Benefit Analysis

In addition to introducing the technical heat delivery solution proposed for Bunhill 2, the expected benefits of the scheme have been evaluated in relation to the operating costs and carbon emissions. A spreadsheet based model was developed and used to assess the benefits in terms of carbon and cost savings. The following analysis aims to provide a high-level appraisal of the system's benefits based solely on energy input costs and carbon emissions related to heat delivered, and does not include any other operational costs, such as for staff support and maintenance. The analysis compares a scenario where all the heat demand is met by heat pumps to the previous heating method based entirely on gas boilers that supply communal heat networks, which feed the blocks of flats within each of the buildings. The calculations were based upon the following assumptions:

- A design life of 25 years (2019-2043) for the system;
- Gas boiler efficiency of 80% for the existing communal boilers<sup>15</sup>;

- Carbon emission factors of 0.184 kgCO<sub>2e</sub>/kWh for natural gas and 0.145 kgCO<sub>2e</sub>/kWh for electricity, which are based on the average of projections for long-run marginal factors for the design life of the system<sup>16</sup>;
- Retail fuel prices of 3.89 p/kWh for natural gas and 14.22 p/kWh for electricity, considering the average of central projections for the design life of the system and a commercial/public sector tariff<sup>16</sup>;
- Heat distribution losses of 10% for the primary network, which represent a reasonable assumption as primary losses vary from 3% to 11% depending on the type of heat network<sup>17</sup>.

Using these assumptions and the heat demand of the buildings connected to Bunhill 2, as shown in Table 2, the expected annual carbon and cost savings of a heat pump based waste heat recovery system were calculated and compared to a gas boiler based communal heating system.

| Energy Consumption |   |                                |                           |     |
|--------------------|---|--------------------------------|---------------------------|-----|
| Technology         | Efficiency/COP                          | Heat Demand (MWh)              | Annual Energy Spent (MWh) |     |
| Gas Boilers        | 80%                                     | 11,358                         | 14,198                    |     |
| Heat Pump          | 3.76                                    |                                | 3,323                     |     |
| Carbon Savings     |   |                                |                           |     |
| Technology         | Carbon Factor (kgCO <sub>2e</sub> /kWh) | Emissions (tCO <sub>2e</sub> ) | Annual Savings            |     |
|                    |   |                                | (tCO <sub>2e</sub> )      | %   |
| Gas Boilers        | 0.184                                   | 2,615                          | 2,133                     | 82% |
| Heat Pump          | 0.145                                   | 482                            |                           |     |
| Cost Savings       |   |                                |                           |     |
| Technology         | Energy Tariff (p/kWh)                   | Costs (£)                      | Annual Savings            |     |
|                    |   |                                | £                         | %   |
| Gas Boilers        | 3.89                                    | 552,283                        | 79,778                    | 14% |
| Heat Pump          | 14.22                                   | 472,505                        |                           |     |

**Table 5 – Calculated annual carbon and cost savings of a heat pump system as opposed to communal gas boilers.**

The results of the analysis can be seen in Table 3, which shows that a heat pump based system results in yearly carbon savings of 2,133 tCO<sub>2e</sub>, a decrease of 82% in emissions, showing how waste heat recovery systems can help reducing the carbon footprint associated with heating. This is due to the high energy efficiency of heat pumps and the similar carbon factors for natural gas and electricity, which has considerably decarbonised in recent years and should keep on decarbonising in the future. The cost analysis results demonstrated how heat pumps can lead to annual savings of £79,778 or 14%, which indicates waste heat recovery systems based on heat pumps can be financially attractive, even though the considered electricity tariff is 3.66 times more expensive than the tariff used for natural gas. The financial benefits related of the scheme could be even greater if incentives are taken into account. The application of a RHI payment of 2.69p/kWh, equivalent to the tariff applied to air-source

heat pumps<sup>18</sup>, would result in an extra gain of £305,530, leading to overall savings of £385,308 or 70%.

## 5. Conclusion

The results obtained show the importance of investing in waste heat recovery systems, as they can lead to significant carbon savings compared to conventional heating methods and could become a key technology in fighting Climate Change. Despite leading to operational cost savings, the conducted economic assessment did not consider the capital costs related to heat pumps or the utilisation of the other heat sources within the Energy Centre, which can impact the financial performance of the scheme considerably.

Even though the costs of implementing district scale heat pumps are known to be high, it is anticipated that they might become more attractive in the near future. As their deployment becomes more popular, the capital costs related to waste heat recovery tend to become lower. In addition, as natural gas reserves diminish over the next decades and possible new carbon taxes are introduced, gas prices are likely to rise, making heat pumps a viable alternative for heating. Results also showed how the simple application of the RHI tariff for air-source heat pumps can increase the financial benefits of the scheme and indicated how the introduction of carbon saving incentives by the government could be an important policy to promote the use of low-carbon heat.

Further studies on the Bunhill Heating Scheme will be undertaken as part of a PhD project, which will study the overall system particularly with regard to its technical and financial performance. Bunhill 2 is expected to become operational in 2019. The study will involve investigating the network components and their performances in detail, comparing the design performance with the actual operation of the system. The benefits of the system will also be looked into in more detail, considering seasonal variations, capital costs and other operational costs and issues, as well as any other challenges that might be encountered after Bunhill 2 starts running.

## 6. References

- (1) Committee on Climate Change (CCC). Reducing UK emissions – 2018 Progress Report to Parliament. Available from: <https://www.theccc.org.uk/tackling-climate-change/reducing-carbon-emissions/how-the-uk-is-progressing/> [Accessed 30<sup>th</sup> October 2018].
- (2) Department for Business, Energy & Industrial Strategy (BEIS). Heat Networks Investment Project, Introduction to the Scheme. Available from: <https://www.gov.uk/government/publications/heat-networks-investment-project-hnip-scheme-overview> [Accessed 21<sup>st</sup> November 2018].

- (3) European Environment Agency (EEA). Renewable energy in Europe 2017. Europe. Available from: <https://www.eea.europa.eu/publications/renewable-energy-in-europe> [Accessed 28<sup>th</sup> October 2018].
- (4) Greater London Authority (GLA). London Environment Strategy. Available from: <https://www.london.gov.uk/what-we-do/environment/london-environment-strategy> [Accessed 30<sup>th</sup> October 2018].
- (5) The Association for Decentralised Energy (ADE). Market Report: Heat Networks in the UK. Available from: <https://www.theade.co.uk/resources/publications/market-report-heat-networks-in-the-uk> [Accessed 4<sup>th</sup> November 2018].
- (6) Davies G, Boot-Handford N, Grice J, Dennis W, Rami R, Nicholls A, Maidment GG. Metropolitan Integrated Cooling and Heating. ASHRAE Winter Conference, Las Vegas, USA. ASHRAE, 2017.
- (7) Duffy S. Opportunities to Utilise Transport for London's Secondary Heat Sources. CIBSE Technical Symposium, London, UK. CIBSE, 2018.
- (8) Islington Council. Islington Council's GIS System. Available from: <http://mapapp.islington.gov.uk/mapthatol/Login.aspx?user=public> [Accessed 16<sup>th</sup> November 2018].
- (9) Jones WP. Air Conditioning Engineering. Edward Arnold, 1985. 421-480.
- (10) Meteorological Office (Met Office). Islington Climate Information. Available from: <https://www.metoffice.gov.uk/public/weather/climate/gcpvjttwz> [Accessed 23<sup>rd</sup> October 2018].
- (11) Maidment G, Baig S, Perris D, Boot-Handford N, Paurine A, Gilbey M, Wegner M, Dragoni F. An Investigation of Cooling Unit Performance on the London Underground Railway Network. CIBSE Technical Symposium, Edinburgh, UK. CIBSE, 2016.
- (12) Kwon O, Cha D, Park C. Performance evaluation of a two-stage compression heat pump system for district heating using waste energy. *Energy*. 2013, 57: 375-381.
- (13) Arpagaus C, Bless F, Schiffmann J, Bertsch SS. Multi-temperature heat pumps: A literature review. *International Journal of Refrigeration*. 2016, 69: 437-465.
- (14) Stoecker WF, Jones JW. Refrigeration and air conditioning. McGraw-Hill, 1982. 281-295.
- (15) BRE Group. Standard Assessment Procedure, version 10 (SAP 10). Available from: <https://bregroup.com/sap/sap10> [Accessed 26<sup>th</sup> November 2018].

- (16) Department for Business, Energy & Industrial Strategy (BEIS). Green Book supplementary guidance: valuation of energy use and greenhouse gas emissions for appraisal. Available from: <https://www.gov.uk/government/publications/valuation-of-energy-use-and-greenhouse-gas-emissions-for-appraisal> [Accessed 13<sup>th</sup> February 2019].
- (17) Department of Energy & Climate Change (DECC). Assessment of the costs, performance and characteristics of UK heat networks. Available from: <https://www.gov.uk/government/publications/assessment-of-the-costs-performance-and-characteristics-of-uk-heat-networks> [Accessed 26<sup>th</sup> November 2018].
- (18) Office of Gas and Electricity Markets (Ofgem). Non-Domestic Renewable Heat Incentive (RHI). Available from: <https://www.ofgem.gov.uk/environmental-programmes/non-domestic-rhi> [Accessed 28<sup>th</sup> November 2018].

### **Acknowledgments**

The authors would like to acknowledge the support from London South Bank University, Transport for London and the Engineering and Physical Sciences Research Council (EPSRC) sponsored project Low Temperature Heat Recovery and Distribution Network Technologies (LoT-NET). The authors are also grateful to Rodrigo Matabuena, Stephen Mirkovic, Graeme Low and James Wilson of the London Borough of Islington for their support in providing valuable information for this project.